



## Crane Association of New Zealand Position Paper

# Articulated Non-Slewing Crane Operator Requirements

---

Author: Crane Association of New Zealand

CANZ PP- 002-T

Date: 23 October 2019

## Document Control

<b>File Name</b>	CANZ-PP-002-T-Articulated	
<b>Document Location</b>	CANZ Position Papers-Technical Papers	
<b>Document Status</b>	Approved	
<b>Version Number</b>	Version 1.1	
<b>Issue Date</b>	28-02-2018	
<b>Assigned Responsibilities</b>	Author	Technical Committee / CICA
	Reviewer	Technical Committee
	Reviewer	Scott McLeod - Scrutineer
	Owner / Approver	Council, Crane Association of New Zealand (Inc.)
<b>Next Review Date</b>	February 2019	

## Record of Amendments

Version	Date Issued	Summary of Changes
<b>1.0 Draft</b>	01-06-2016	Draft Issue
<b>1.1 Draft</b>	27-02-2018	Draft Issue for Council Approval
<b>1.1 Final</b>	27-02-2018	Approved

## Contents

<b>Document Control .....</b>	<b>2</b>
<b>Record of Amendments .....</b>	<b>2</b>
<b>1. Crane Association Position.....</b>	<b>4</b>
<b>2. Background.....</b>	<b>4</b>
<b>3. Articulated Non-Slewing Crane Operator Qualifications and Skill Requirements .....</b>	<b>5</b>
<b>4. Comparison of Operating Features of Slewing Mobile Cranes and Articulated Non-Slewing Cranes.....</b>	<b>6</b>
<b>5. Further Information.....</b>	<b>7</b>
<b>Appendix A – Side Slope Deration.....</b>	<b>8</b>
<b>Appendix B – Crane Articulation .....</b>	<b>10</b>

### *Disclaimer and Copyright*

*This Crane Association of New Zealand (Inc) Position Paper has been compiled for general information only, is not to be considered as a substitute for professional advice, and should not be treated as an exhaustive statement on the subject. The Crane Association of New Zealand (Inc) accepts no responsibility for the accuracy, completeness or currency of the material included in this Position Paper.*

*Users of this Position Paper are encouraged to obtain professional advice and to exercise their own skill and care in relation to any of its material.*

*The Crane association of New Zealand (Inc) disclaims any and all liability or responsibility for any loss or damages arising out of any use of, or reliance on, this Position Paper.*

*This Position Paper is copyright. Readers may use and reproduce this material in an unaltered form only for non-commercial use within their own organisation.*



## 1. Crane Association Position

It is the position of the Crane Association of New Zealand (Inc.) (CANZ) that:

Articulated non-slewing crane design, manufacturing, and testing are regulated by standards, safety regulations and industrial codes of practice. Numerous modern technology and materials are applied and used on the Articulated non-slewing cranes by crane manufacturers to make sure these sophisticated, state of the art machines are safe to operate under different conditions.

Articulated non-slewing crane operators need to be familiar with the behaviour of the crane and follow manufacturer's instructions to perform safe lifting operations with them.

CANZ recommends that all operators of articulated non-slewing cranes undertake New Zealand Certificate qualifications training which includes technical and theoretical information competency assessment and familiarization training including practical demonstrations should be conducted under supervision.

The CANZ training CD "Safe use of Articulated Non-Slewing Pick & Carry Cranes"<sup>i</sup>, was developed by the Crane Industry Council of Australia technical committee with contributions from crane manufacturers and experienced crane operators and assessors. The training pack may be used as refresher training materials for crane operators, dogging and rigging crews and supervisors for training and competency assessment.

## 2. Background

Articulated non-slewing crane operation is unique to the operation of other types of mobile cranes. Crane operators who operate articulated non-slewing cranes must operate the crane according to the manufacturer's instructions. Their competency for articulated non-slewing crane operation should be verified independently of slewing crane operation competency.

An articulated non-slewing crane (a variant of non-slewing cranes) is a type of mobile crane that is designed to travel on public roads and is designed to lift and often carry a load to its destination. Different from slewing mobile cranes, articulated non-slewing cranes normally do not have stabiliser legs or outriggers; they have a permanent articulation joint in their construction, allowing the crane to manoeuvre and place loads. They are designed to national or international standards. Examples of these standards are Health & Safety in Employment (Pressure Equipment, Cranes, and Passenger Ropeways, Approved Code of Practice for Cranes 2009 and Australian Standard 1418.5. Further information can be found in the Crane Safety Manual.

Articulated non-slewing cranes have displaced the work usually completed by smaller hydraulic truck cranes as the setup time is significantly shorter, and the load can be picked up and carried by the crane to the destination.

Many accidents have been reported involving articulated non-slewing cranes due to crane operators not following manufacturer instructions for site conditions, lifting conditions or being un-familiar with the operation of articulated non-slewing cranes, in particular, driving the crane on the open road.



**FIGURE 1: ARTICULATED NON-SLEWING CRANE CRASHED THROUGH A MOTORWAY BRIDGE**

### 3. Articulated Non-Slewing Crane Operator Qualifications and Skill Requirements

The Crane Association recommends that a person who operates an Articulated Non-Slewing Crane holds a minimum of Unit Standard 24511 or equivalent in accordance with the Code of Practice for Cranes, 2009 and the appropriate driver's license.

It is desirable for an operator to have the New Zealand Certificate in Crane Operations, Level 3, Non-Slewing Articulated Non-slewing crane Strand <sup>ii</sup>. An operator must show competency under legislation to qualify and must be able to:

- Carry out all necessary pre-operational checks;
- Prepare a safe operational plan to deal with typical hazards and control the risks arising from those hazards;
- Set-up the crane;
- Understand and interpret load charts and data plates;
- Respond to hand and whistle signals for load movement;
- Calculate the safe working loads of slings in various configurations;
- Inspect lifting gear for defects;
- Assess the weight of loads;
- Operate the crane under actual or simulated working conditions;
- Understand the use of various items of lifting gear; and
- Shut down and secure the crane.

## 4. Comparison of Operating Features of Slewing Mobile Cranes and Articulated Non-Slewing Cranes

Even though crane operator skill requirements are similar between different types of cranes, articulated non-slewing cranes have their special operating features that differentiate themselves from other types of mobile cranes, i.e. slewing mobile cranes.

Contrary to slewing mobile cranes, articulated non-slewing cranes typically do not have stabiliser legs or outriggers; crane stability is gained entirely from the crane tyres. Crane rated capacities on tyres depend on tyre capacity, the condition of the tyres, tyre air pressure [Figure 2(a)] and ground condition. All tyres must be checked and inflated to the recommended pressure before lifting. The ground shall be examined to understand ground conditions. The crane shall be set up on a firm, level (max.1% slope / 0.5 °) and uniform surface. The crane operator shall read and fully understand the manufacturer's instructions for site conditions and lifting conditions before conducting the lift<sup>iii</sup>.

During the lifting operation, slewing mobile cranes usually lift the load from a fixed location, whereas articulated non-slewing cranes often travel on sites with their load. When operating the crane to lift and carry a load, the crane operator shall follow the manufacturer's instructions. Adverse operating conditions should be considered, including the supporting surface, pendulum action of the load, jerking or sudden stops of the load and other factors affecting stability. The rated lifting capacities are based on freely suspended loads with the crane on a firm, level (max.1% slope / 0.5 °)<sup>iv</sup> and uniform surface. Crane operators shall take into consideration changing ground conditions that can occur when travelling while carrying loads, as changing ground conditions (uneven road surface, potholes, etc.) will cause a reduction in crane rated capacity. See below Figure 2(b) and Figure 2(c) for examples of crane stability problems caused by changing ground conditions when travelling on road. These conditions effectively create a side slope condition, and the rated capacity of the crane reduces to ensure the crane remains stable. Manufacturer's instructions should be followed for operating on a side slope. If no deration chart or instruction is given on side slope operation, crane shall not be operated on a side slope.

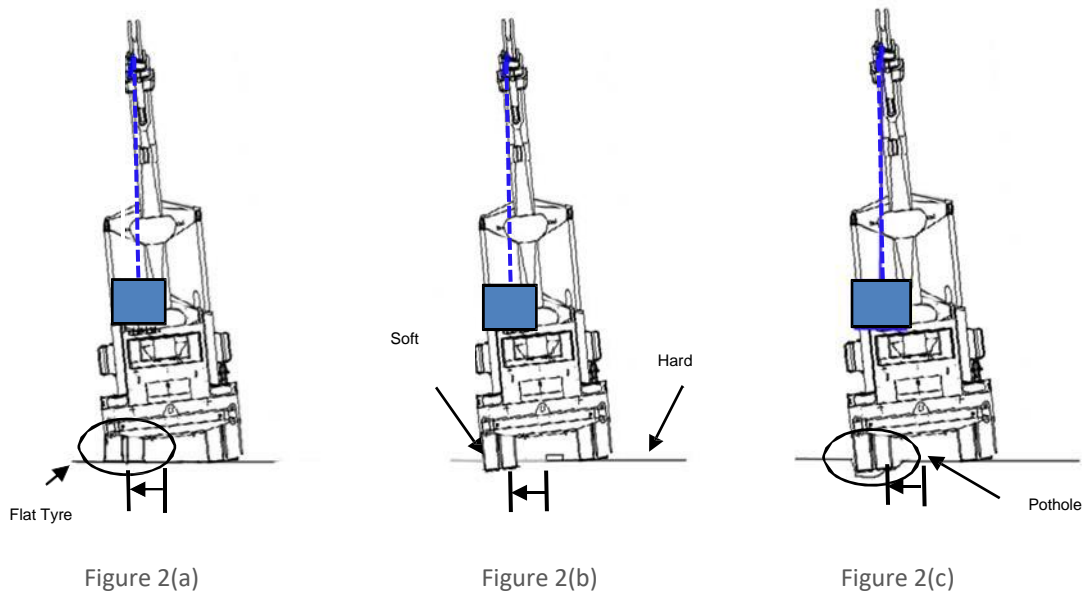

**Figure 2: Crane stability problems caused by (a) using incorrect tyre pressure (b) changing ground conditions and (c) pothole on the ground**

When lifting a load on a side slope, it induces a side load as the load swings down the slope, and this affects the tipping line of the crane. Crane operators shall follow the deration percentage specified on the deration load chart provided by the crane manufacturer to calculate the appropriate crane rated capacity for their lifting job. See Appendix A for examples of how to use the side slope deration chart.

A combination of crane articulation and ground side slope can cause serious problems for crane stabilization, crane travelling path analysis and de-rating calculation of the crane lifting capacity must be conducted during the work planning phase, crane side slope indicators shall be correctly interpreted, and crane side-slope chart must be used.

Unlike slewing mobile cranes that can perform lifting operations with a slewing angle of 360°, the articulated non-slewing crane's operation is only permitted through the crane articulation range, typically up to 40°. Most articulated non-slewing cranes have a reduced rated capacity above 10° articulations. During crane articulation, the crane's centre of gravity gets closer to the axis of rotation which causes the movement from the crane counterweight to be reduced. A reduced rated capacity chart has to be used if entering the articulation range of 10° to 40° during the operation (as illustrated in Appendix B).

## 5. Further Information

This Position Paper contains summary information only and further information is available by contacting the Crane Association of New Zealand (Inc.)

Contact Details	
<b>Postal Address:</b>	PO Box 12013, Wellington 6144
<b>Physical Address:</b>	21 Fitzherbert Terrace, Thorndon, Wellington
<b>Telephone:</b>	+64 4 473 3558
<b>Email:</b>	info@cranes.org.nz



## Appendix A – Side Slope Deration

Figure A-1 is an example of an Articulated Non-slewing crane lifting load on side slope. Lifting on a side slope induces a side load as the load swings down the slope and this affects the tipping line of the crane. Any deviation to firm level conditions requires the rated capacity to be reduced accordingly to the manufacture's recommendations.

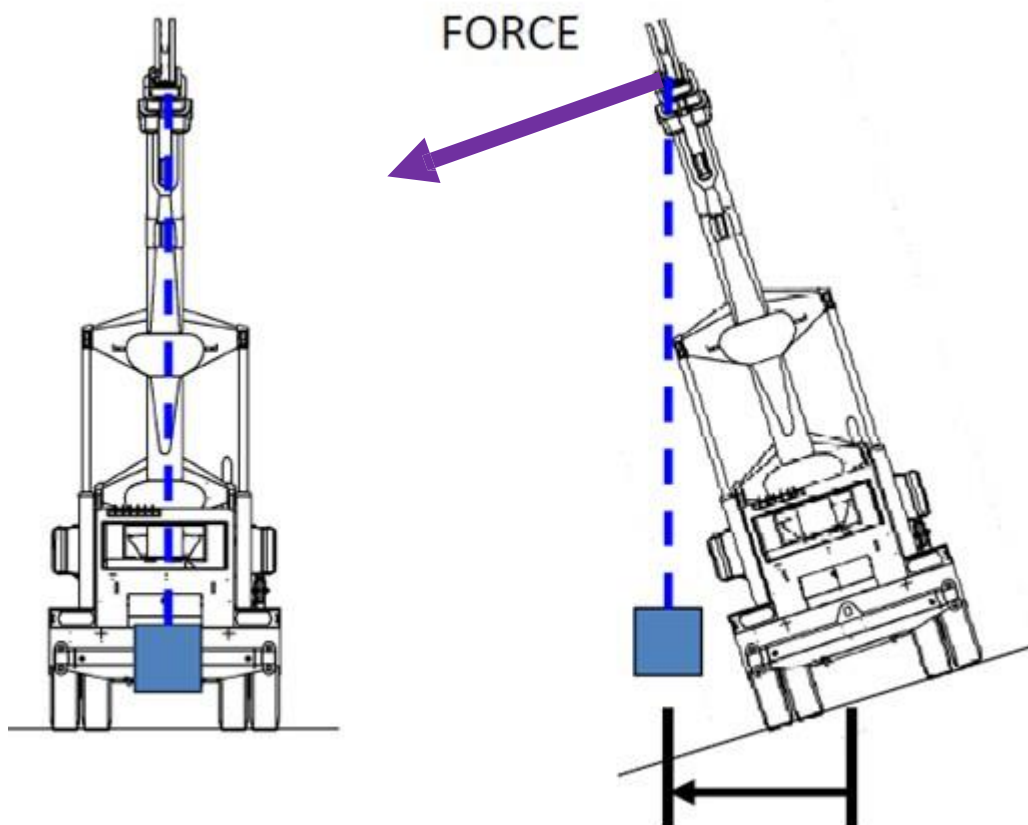

**Figure A-1: Articulated Non-slewing crane travel on side slope**

Figure A-2 is an example of a crane capacity deration chart. The deration load charts are provided by manufacturers to guide the operator how to calculate the rated capacity reduction when a side slope is encountered. Crane operators shall follow the deration percentage specified on the chart to calculate the appropriate crane rated capacity for their lifting configuration and environment.



If a crane with a deration load chart below has a rated capacity of 4000kg (operating at 10m working radius with a boom angle of 30°), when it's operating on a side slope up to 5°, according to the chart, the crane capacity shall reduce 40% to:

$$4000\text{kg} - 4000\text{kg} \times 40\% = 2400\text{ kg (point (1))}$$

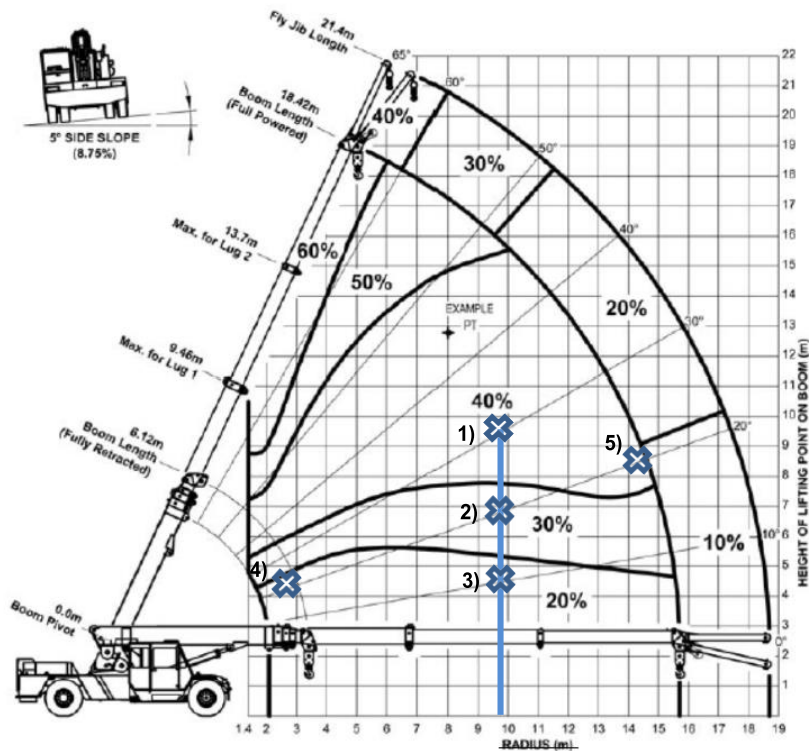

Figure A-2: Example crane capacity deration chart

According to Figure A-2, when a crane is operating at 10m working radius on a surface with a side slope up to 5°:

- 1) If the boom is operating at 30° angle, the rated capacity of the crane shall be reduced by 40%.
- 2) If the boom is operating at 20° angle, the rated capacity of the crane shall be reduced by 30%.
- 3) If the boom is operating at 10° angle, the rated capacity of the crane shall be reduced by 20%.

When the crane is operating at 20° boom angle on a surface up to a 5° side slope:

- 4) If the boom length is 6.12m, the rated capacity of the crane shall be reduced by 20%
- 5) If the boom length is 18.42m, the rated capacity of the crane shall be reduced by 40%.

It is important to keep the boom length and angle to a minimum when operating on side slope.

## Appendix B – Crane Articulation

The crane tipping line changes during crane articulation. The position of crane centre of gravity gets closer to the axis of rotation which causes the moment from the crane counterweight to be reduced.

### STEERING ARTICULATION

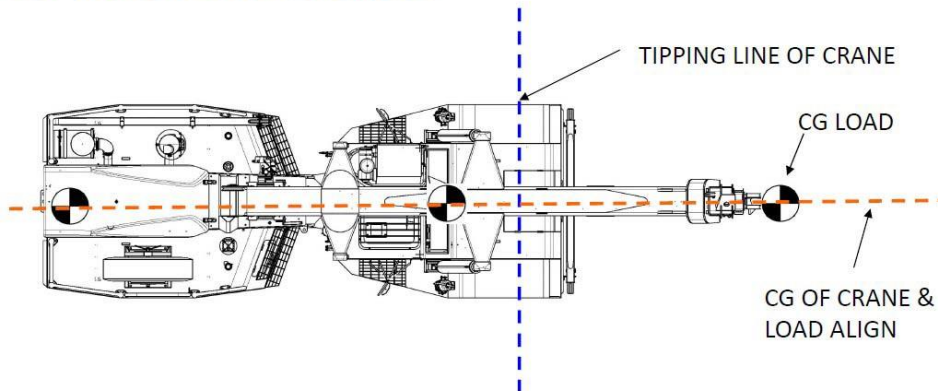

Figure B-1: Articulated Non-slewing crane in non-articulation configuration

### STEERING ARTICULATION

Distance of counterweight to prevent tipping is REDUCED when ARTICULATED & CG offset inducing side load.

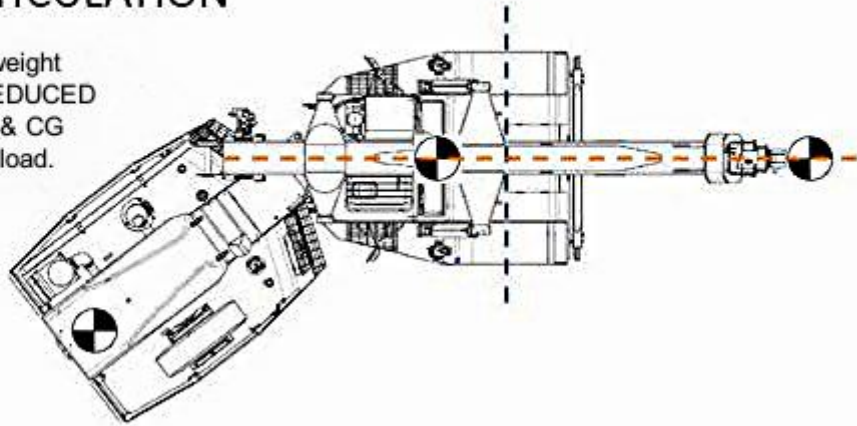

Figure B-2: Articulated Non-slewing crane in articulation configuration

\*Tipping line change as shown in Figure B-1 and B-2 applies to all type of articulated non-slewing cranes

Refer to the example articulated non-slewing crane load chart below. In the chart, crane rated capacity for crane articulation angle less than 10° (in green) and crane articulation angles greater than 10° (in yellow) are listed. Stability reduces the rated capacity of the crane when the crane articulates more than 10°.

RADIUS	BOOM LENGTH (m)																	
	5.67	6.00	6.50	7.00	7.50	8.00	8.50	9.00	9.50	10.00	10.50	11.00	11.50	12.00	12.50	13.00	13.50	13.85
1.6	16800	16250	15450	14900														
	12600	12600	12600	12600														
2.0	1800	1800	1800	18700	15100	14700	14350											
	12600	12600	12600	12600	12600	12600	12600											
2.5	13900	13900	13900	13850	13850	13850	13850	13200	3000									
	12150	12150	12100	12100	12100	12100	12100	12050	2050									
3.0	11450	11450	11450	11400	11400	11400	11400	11400	11400	11150	10250							
	9950	9950	9950	9950	9950	9950	9950	9900	9900	9900	9900							
3.5	9650	9650	9650	9650	9650	9650	9650	9650	9650	9500	8150	7500						
	8400	8400	8400	8400	8400	8400	8400	8400	8350	8350	8350	8150	7500					
4.0	9450	8550	8350	8350	8350	8350	8350	8350	8300	8300	8300	7600	7000	6700	6450			
	8200	7450	7250	7250	7250	7250	7250	7250	7200	7200	7200	7000	6700	6450				
4.5			6500	6350	6350	6350	6350	6350	6300	6300	6300	6300	6250	6050	5800	5650		
			(4.40)	19	27	34	38	42	45	48	50	52	54	56	58	59	60	
5.0			6650	6500	6500	6500	6500	6500	6500	6500	6500	6500	6150	5900	5650	5450	5300	5150
			5750	5600	5600	5600	5600	5600	5600	5600	5600	5600	5600	5600	5600	5450	5300	5150
6.0				5950	5350	5250	5250	5250	5250	5250	5250	5250	5250	5050	4850	4700	4600	
				5100	4600	4550	4550	4550	4500	4500	4500	4500	4500	4500	4500	4500	4500	4500
7.0					4850	4450	4400	4400	4400	4400	4400	4400	4350	4350	4350	4200	3950	
					4200	3800	3750	3750	3750	3750	3750	3750	3750	3750	3750	3750	3750	3750
8.0									4100	3750	3700	3700	3700	3700	3700	3700	3700	3600
									3500	3200	3150	3150	3150	3150	3150	3150	3150	3150
9.0																		
10.0																		
11.0																		
11.75																		

SWL (KG) LESS THAN 10 DEG ARTICULATION  
 SWL (KG) GREATER THAN 10 DEG ARTICULATION  
 BOOM ANGLE

Weight of slings & hook block to be added to load  
 Read and understand warning notes before operating crane  
 Loads above bold red line are structural

Figure B-3: Example articulated non-slewing crane load chart

When crane is operating with a 9 meter boom at 4 metre radius,

- 1) Rated capacity of the crane is 8350kg when the crane is Articulated Non-Slewing less than 10°, or
- 2) Rated capacity of the crane is 7250kg when the crane is Articulated Non-Slewing more than 10°, boom angle is 47° for both cases.

Endnotes

i Crane Training Shop (<http://shop.cranes.org.nz>)  
 ii Crane Safety Manual Ver. 3 2015  
 iii Crane Manufacturers Specifications  
 iv Crane Safety Manual